

MODELS A106-DL-AIR / A106-DL-AIR-ET DYNAMIC LIFTER® AIR OPERATED PRESSURE RELIEF VALVE SURGE ANTICIPATING ELECTRONICALLY TIMED DL PRESSURE RELIEF VALVE

KEY FEATURES

A106-DL-AIR:

- Eliminates surges and prolongs pipe life
- Adjustable closing speed
- Utilizes compress air or plant air
- Smaller profile allows installation into limited space
- Ideal for higher pressures

A106-DL-AIR-ET:

- All key features of the A106-DL-Air
- Solenoid valve anticipates surges resulting from power failures



PRODUCT OVERVIEW

The Model A106-DL-Air is a compact sewage relief valve that is suitable for high pressures up to 200 psi / 13.8 bar, responds very quickly and retains all the features and benefits of the Model A106-DL Spring-Hydraulic version. It is an attractive solution to what may be otherwise a difficult application due to higher pressures or space height limitations.

The Model A106-DL-Air-ET retains all the features and benefits of the Model A106-DL-Air with the additional feature of two 3-way solenoid valves which forces the valve open upon power failure.

TYPICAL APPLICATION

Application drawing is applicable to both A-106-DL-Air and A-106-DL-Air-ET.

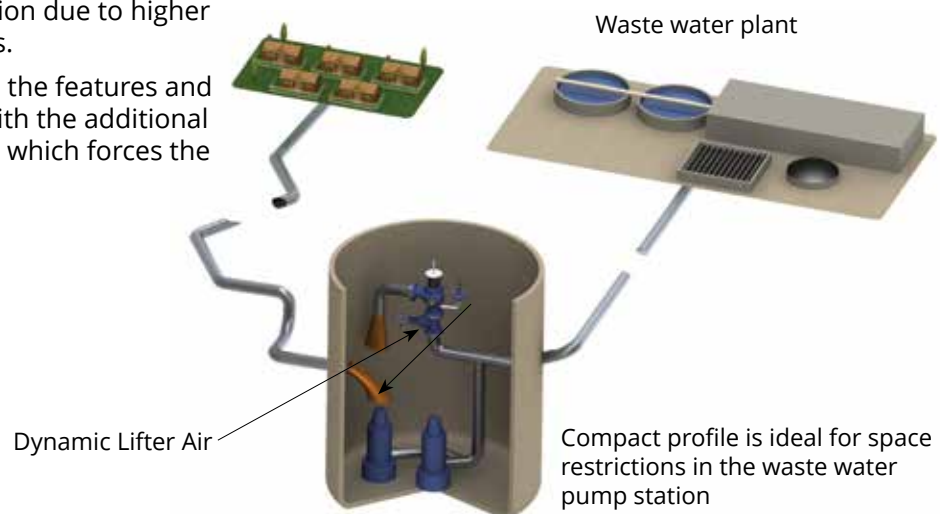

MODEL A106-DL-AIR DYNAMIC LIFTER® AIR OPERATED PRESSURE RELIEF VALVE

SCHEMATIC DRAWING A106-DL-AIR

1. Model A106-DL-Air
2. Isolating Valve (2A, 2B)
3. Needle Valve
4. Pressure Reducing Pilot - Model 160
5. Relief Pilot - Model 81-RP
6. Pressure Gauge (6A, 6B)
7. Fixed Restriction
8. Isolating Valve
9. Diaphragm Isolator
10. Bleed Valve
11. Check Valve, J0040A
12. Bleed Valve
13. Manual Override Valve
14. Fixed Restriction
15. Air Supply
16. 852B Needle Valve
17. Air Charge Valve
18. Isolating Valve
19. Isolating Valve

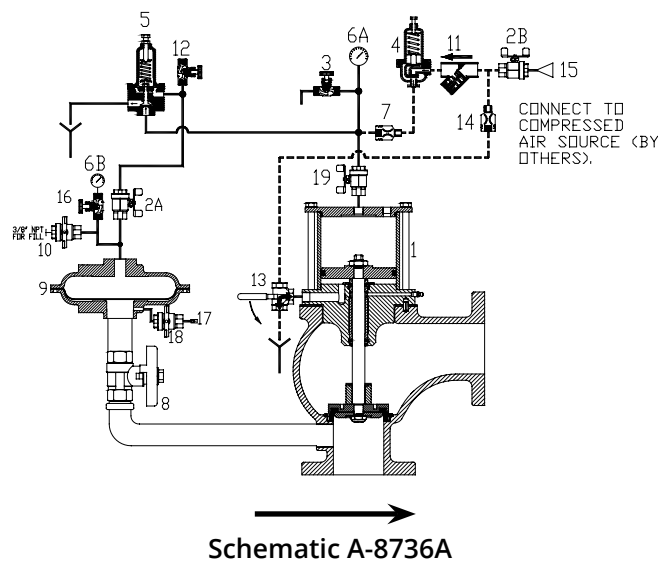

SCHEMATIC DRAWING A106-DL-AIR – OPERATION DETAILS

Operates using separate compressed air supply
 - An inexpensive 120 psi / 8.3 bar air compressor may be used for 200 psi / 13.8 bar or higher relief pressures by using a large diameter closing piston.

Using a chamber and diaphragm isolator (9), an accurate hydraulic pilot (5) opens reliably and repeatedly at its set pressure (gauge 6A)
 - Full operational (including pilot) check is quickly and cleanly performed by closing valve (8) and applying pressure at (18). For quick flush open (3).

The check valve (11) maintains air in the operating cylinder should the air supply fail.
 - Provided the air supply is above minimum, variations in pressure do not affect the valve operation, which is controlled independently by the accurate pilot (5).

The main valve (1) is constructed of the same premium materials as the Hydraulic Dynamic Lifter for long life and minimum maintenance.

MODEL A106-DL-AIR-ET SURGE ANTICIPATING ELECTRONICALLY TIMED DYNAMIC LIFTER® PRESSURE RELIEF VALVE

SCHEMATIC DRAWING A106-DL-AIR-ET

1. Model A106-DL-Air
2. Isolating Valve (2A, 2B)
3. Needle Valve
4. Pressure Reducing Pilot - Model 160
5. Relief Pilot - Model 81-RP
6. Pressure Gauge (6A, 6B)
7. Fixed Restriction
8. Isolating Valve
9. Diaphragm Isolator
10. Bleed Valve
11. Check Valve, J0040A
12. Bleed Valve
13. Solenoid Valve - 3 way - NC
14. Solenoid Valve - 3 way - NO
15. Air Supply
16. 852B Needle Valve
17. Air Charge Valve
18. Isolating Valve
19. Optional SAP control panel

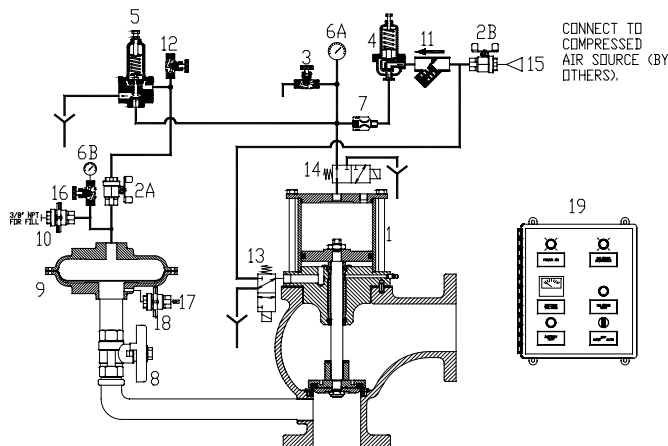

A106-DL-Air-ET
Schematic A-8809A

SCHEMATIC DRAWING A106-DL-AIR-ET – OPERATION DETAILS

Operates using separate compressed air supply
 - An inexpensive 120 psi / 8.3 bar air compressor may be used for 200 psi / 13.8 bar or higher relief pressures by using a large diameter closing piston.

Using a chamber and diaphragm isolator (9), an accurate hydraulic pilot (5) opens reliably and repeatedly at its set pressure (gauge 6A)
 - Full operational (including pilot) check is quickly and cleanly performed by closing valve (8) and applying pressure at (18). For quick flush open (3).

The check valve (11) maintains air in the operating cylinder should the air supply fail.
 - Provided the air supply is above minimum, variations in pressure do not affect the valve operation, which is controlled independently by the accurate pilot. The main valve (1) is constructed of the same premium materials as the Hydraulic Dynamic Lifter for long life and minimum maintenance.

Two 3-way solenoids are included to force the valve open on power failure. A backup control panel is required to time the reclosure.

The solenoids convert the relief valve function to a surge anticipating valve if needed, particularly if there is a risk of the system going sub-atmospheric. Air pressure through solenoid holds the valve open until closed by the electrical controls

ORDERING INSTRUCTIONS

Refer to page 244 for the order form and ordering instructions.

MODEL A106-DL-AIR DYNAMIC LIFTER® AIR OPERATED PRESSURE RELIEF VALVE MODEL A106-DL-AIR-ET SURGE ANTICIPATING ELECTRONICALLY TIMED DL PRESSURE RELIEF VALVE

A106-DL ANSI DATA (US UNITS)	AIR OPERATED			
Size	3 in	4 in	6 in	8 in
	Relief Settings (psi)			
Pressure Ranges	Options Available up to 200 PSI, consult with Singer Valve			
Lift / Opening	2 in	2 in	2 1/2 in	3 in
Dimension A	9 in	10 in	11.5 in	14 in
Dimension B*	22.5 in	23.5 in	25.5 in	28.88 in
Dimension C	30.5 in	30.5 in	32 in	32 in
Dimension D	4.75 in	5.75 in	7.5 in	10 in

A106-DL ANSI DATA (METRIC UNITS)	AIR OPERATED			
Size	80 mm	100 mm	150 mm	200 mm
	Relief Settings (bar)			
Pressure Ranges	Options Available up to 13.8 Bar, consult with Singer Valve			
Lift / Opening	50 mm	50 mm	64 mm	76 mm
Dimension A	229 mm	254 mm	292 mm	356 mm
Dimension B*	572 mm	597 mm	648 mm	734 mm
Dimension C	775 mm	775 mm	813 mm	813 mm
Dimension D	121 mm	146 mm	191 mm	254 mm

Pneumatic operational ranges up to 200 psi / 13.8 bar.
Consult Singer Valve for more information on higher pressures.

*Dimension B reflects clearance allowed for pilot system and accessories

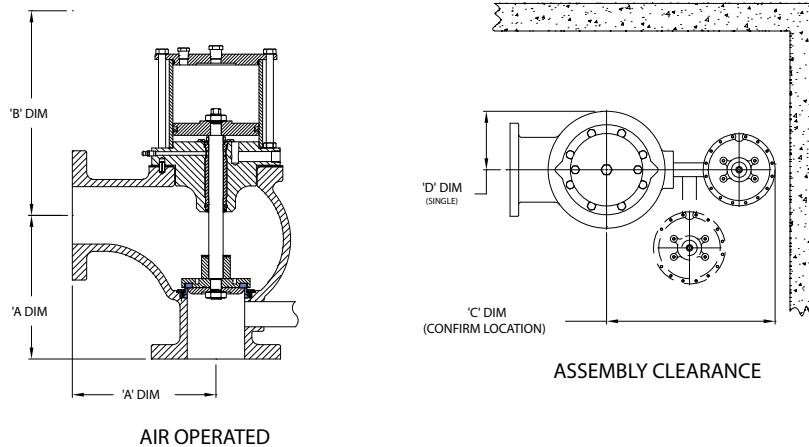

Dynamic Lifter Sizing Graph Curve: 3 in / 80 mm – 8 in / 200 mm
 Conventional relief valves for sewage are typically sized "larger" than a
 Singer Valve Dynamic Lifter due to opening forces being lost as the inner valve leaves the seat.

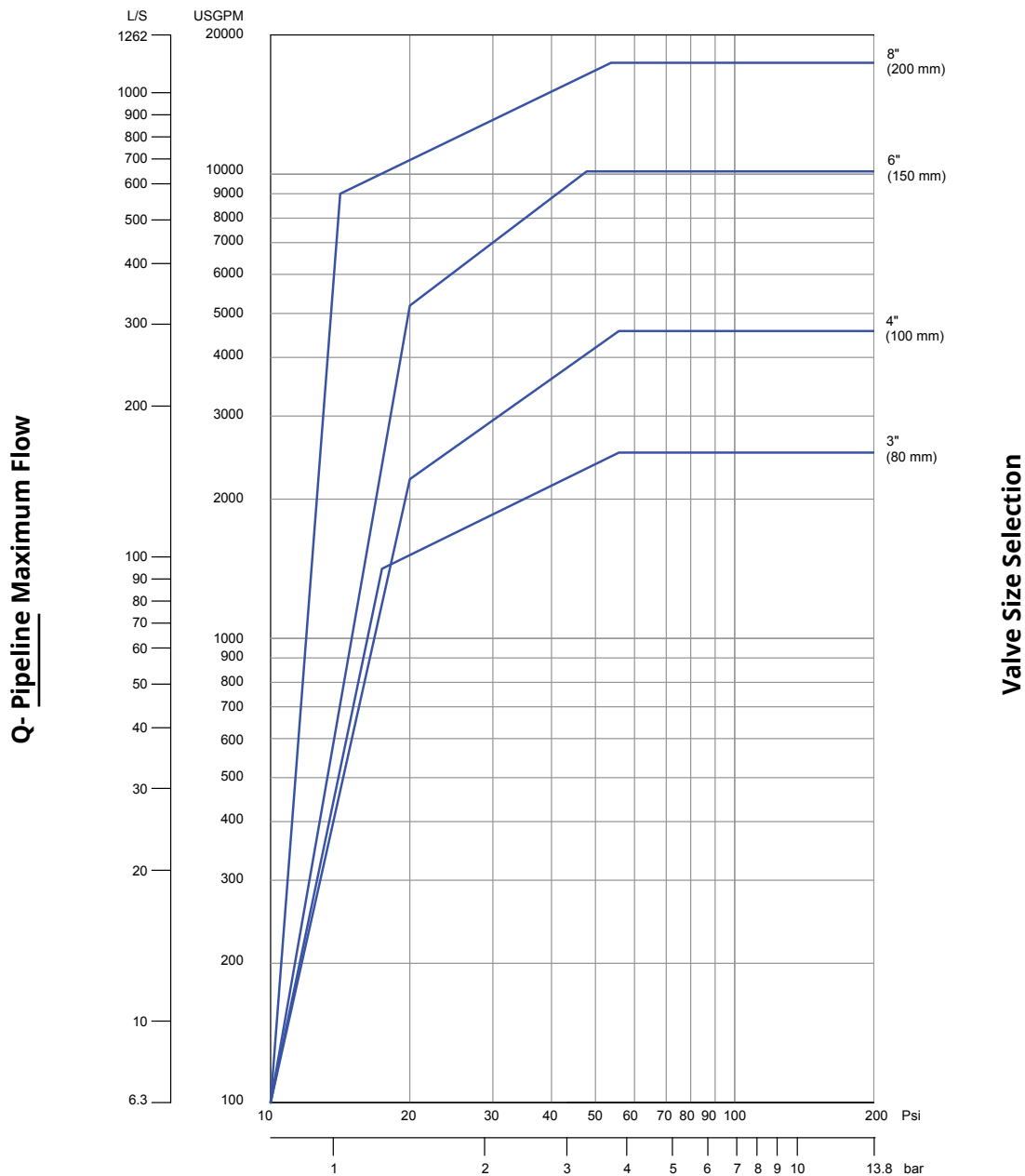

ΔP - Minimum pressure drop across dynamic lifter.

Examples of valve size selection:

- 1) Relief setting 80 psi / 5.5 bar - discharge to atmosphere: Max. flow in main pipeline 1,200 USGPM / 75.7 l/s - Find intersect of 80 psi / 5.5 bar ΔP and 1200 USGPM / 75.7 l/s flow. Select next larger size Dynamic Lifter, for example, 3 in / 80 mm size.
- 2) Relief setting 55 psi / 3.8 bar - discharge 20 psi / 1.38 bar back pressure: Max. flow in main pipeline 4,000 USGPM / 252.4 l/s Find intersect of 55 psi - 20 = 35 psi / 2.4 bar ΔP and 4000 USGPM / 252.4 l/s flow. Select next larger size Dynamic Lifter, for example, 6 in / 150 mm size.

Note:

if the discharge was to atmosphere, $\Delta P = 55$ psi / 3.8 bar and 4 in / 100 mm size would be selected.

this graph is based on current practice for standard applications. It is intended to be a guide only and no selection guarantee is implied or intended.